

# CU20/C TYPE

Solenoid protection rate: IP40  
 Insulation class: E (120°C)  
 Cycle duration: 4 minutes  
 Standard stroke "s": 6 mm  
 Temperature rise: "ΔV<sub>31</sub>" 70°C  
 Work: pull/push  
 Incorporated return spring: YES

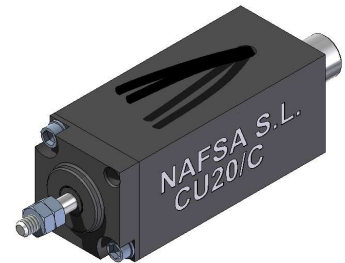

Duty-cycle ED(%)	100	40	25	15	5
Abs. Power at 20°C (W)	4	10	16	26	80
Minimum force (N)	0.9	2.1	2.5	3.1	5.5
Max time under voltage(s)	∞	96	60	36	12
Plunber weight (g)	18				
Solenoid weight (g)	110				

Duty-cycle ED%	Standard voltages								Under demand voltages				
	VDC						VAC		VDC		VAC		
	6	12	24	48	100	125	205	110	230	Min	Max	Min	Max
100%	o	o	o	o	o	x	x	x	x	3	110	x	x
40%	o	o	o	o	o	o	x	x	x	3	175	x	x
25%	o	o	o	o	o	o	o	x	x	3	220	x	x
15%	o	o	o	o	o	o	o	x	x	4	250	x	x
5%	o	o	o	o	o	o	o	x	x	6	250	x	x

Layout: o = Available ; x = Unavailable

- 1) Under demand voltage: They can be manufactured at any voltage between the maximum and minimum voltage values shown in the chart.
- 2) To feed in alternating current the solenoid will have an external rectifier
- 3) The duty-cycle described in the chart are standard, they can be manufactured in any intermediate cycle.
- 4) If any variation from the original is needed, please ask us.
- 5) Earthing is recommended if the metallic parts are accessible.

## Solenoid under voltage

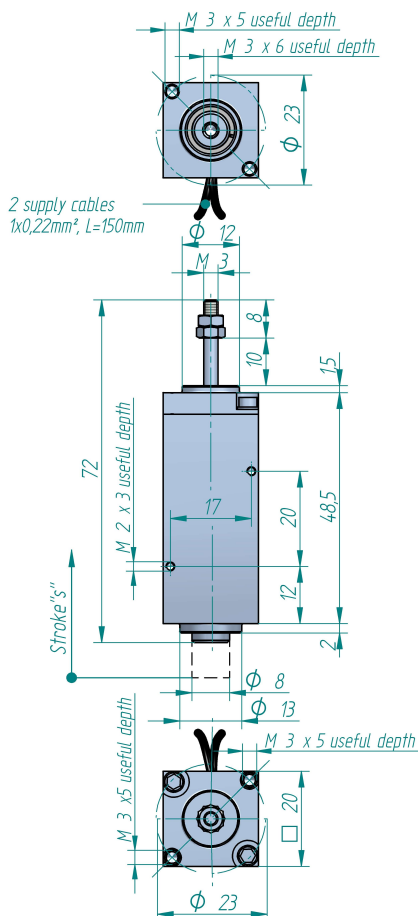

## Force-stroke curve

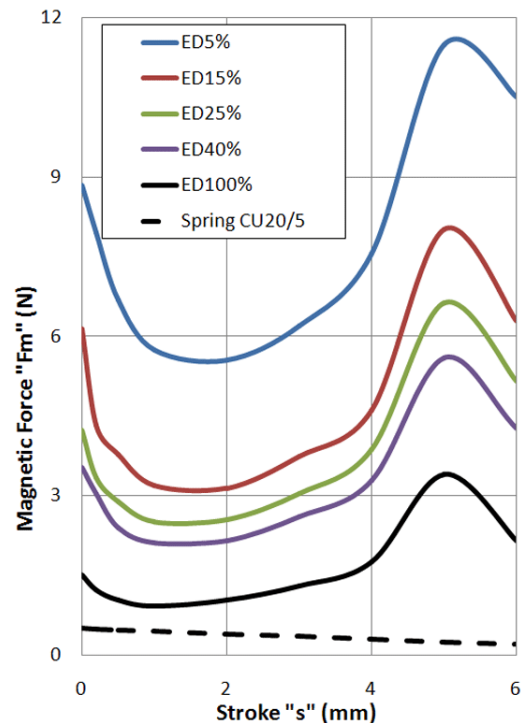

Calculation of the effective force: see pages 1 and 52

Ordering code: CU20/C --V ED---%

Example:  
 Standard voltage: 24Vdc Duty-cycle: ED100%: with spring :  
 Ref.: CU20/C 24Vdc ED100% RS  
 Standard voltage: 12Vdc Duty-cycle: ED15%: without spring :  
 Ref.: CU20/C 12Vdc ED15% RN