



TÁPEGYSÉG 1 FÁZIS, DIMENSION Q SZÉRIA

36-42 V DC, 26,7 A

QS40.361

PSU 100-240V ac I/P 36V dc 26.7A 960W O/P

- 125mm széles
- 94,6%-os hatásfok
- 50 % bónusz teljesítmény 4s
- DC-OK relé, Hiccup Plus, aktív PFC és távoli leállítás

PULS



TERMÉKLEÍRÁS

MŰSZAKI ADATOK

DC relay output	Igen
Efficiency At 120 V AC, full load. Typical	93,5 %
Efficiency At 230 V AC, full load. Typical	94,6 %
Efficiency At 230 V AC. Typical	93,6 %
Fázisok száma	1
Hold-up time at 120 V AC, full load. Typical.	27 ms
Hold-up time at 230 V AC, full load. Typical.	27 ms
Input voltage AC	100-240 V
Input voltage ac max	264 V AC
Input voltage ac min	90 V AC
Input voltage range	Wide-range
Inrush current at 120 V ac typical	17 A
Inrush current at 230 V ac typical	11 A
IP-osztály	IP20
Jóváhagyások	ABS, CB, CE, CSA, EX, GL, IECEx, UL
Lifetime at 120 V ac, full load and +40 ° C	55000 h
Lifetime at 230 V ac, full load and +40 ° C	58000 h
Magasság	124 mm

Mélység	127 mm
MTBF (IEC 61709) 230 V AC, Maximum Load, 40 ° C	537000 h
Output Current	26,7 A
Output voltage	36 V DC
Output voltage max	42 V DC
Output voltage min	36 V DC
Power Consumption At 120 V AC	8,6 A
Power Consumption At 230 V AC	4,5 A
Power Factor at 120 V AC, full load. Typical	0,99
Power Factor at 230 V AC, full load. Typical	0,99
Power Reduction Of 60 To 70 ° C	24 W/°C
Ripple. max	130 mV pp
Series	Dimension Q
Supply Frequency	50-60 ±6 %
Szélesség	125 mm
Teljesítmény	960 W
Temperature Range Without Derating From	-25 °C
Temperature Range Without Derating To	60 °C
Tömeg	1,9 kg
Védőanyag	Alumínium

Fig. 6-1 Output voltage vs. output current in "single use" mode, typ.

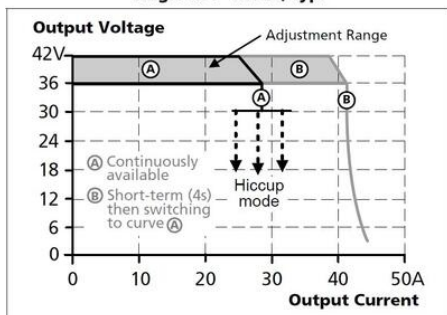

Fig. 6-4 Dynamic overcurrent capability, typ.

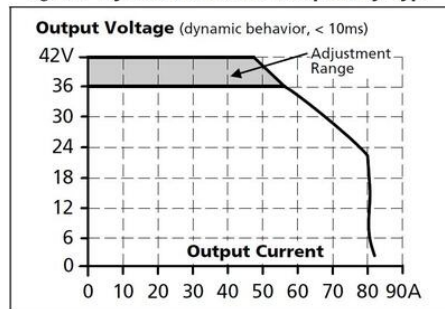

Fig. 18-1 Output current vs. ambient temp.

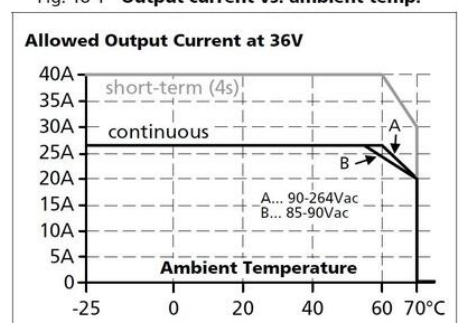

Fig. 6-3 Short-circuit on output, Hiccup^{PLUS} mode, typ.

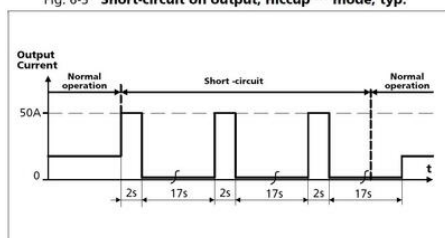

Fig. 12-1 Efficiency vs. output current at 36V, typ.

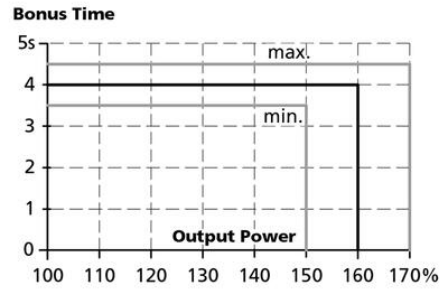
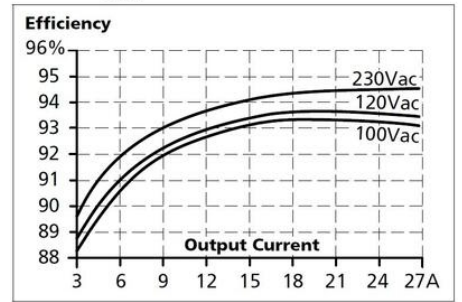

Fig. 12-2 Losses vs. output current at 36V, typ.

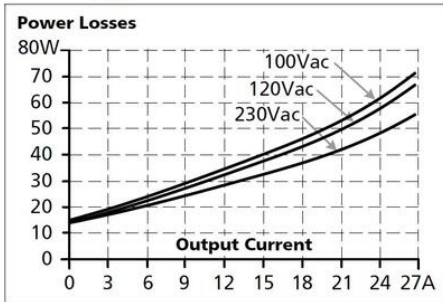

Fig. 16-1 Front side

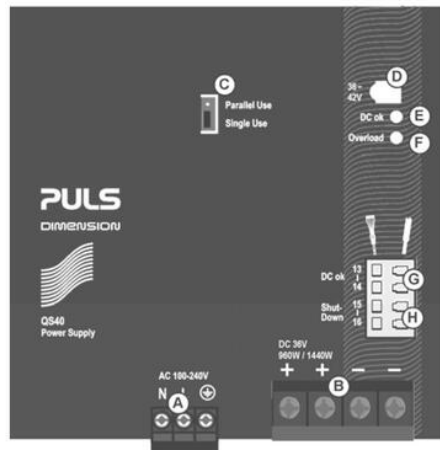

Fig. 23-1 Front view

